

ARUBA

CAUTION: At least two adults are required to safely complete performing this task.
Other lifting attempts may risk back injury due to large and heavy part(s).



ASSEMBLY INSTRUCTIONS

Avoid using sharp objects such as a knife to cut open the packing as you may accidentally damage the upholstery.

1. Carefully place the sofa cushion unit on a clean flat surface with the metal plates facing up.
2. Unpack hardware pack from the zipped storage compartment.
3. Align each of the four legs onto the designated plates in the correct orientation as shown in DIAGRAM 1.
4. Referring to DIAGRAM 2, secure two bolts for each leg with the provided Allen key.
5. Carefully lift and turn assembled unit onto its legs.

PARTS AND HARDWARE



Allen Key
1x



Bolt
8x

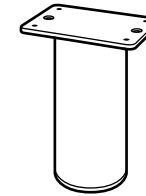

Leg
4x

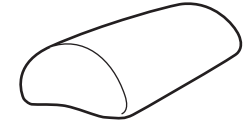

Pillow Cushion
2x

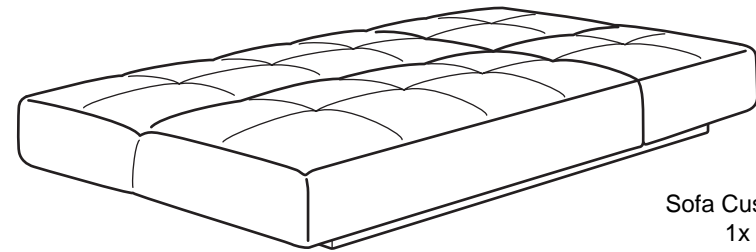

Sofa Cushion
1x

Note: Individual parts are not shown to scale.

DIAGRAM 1

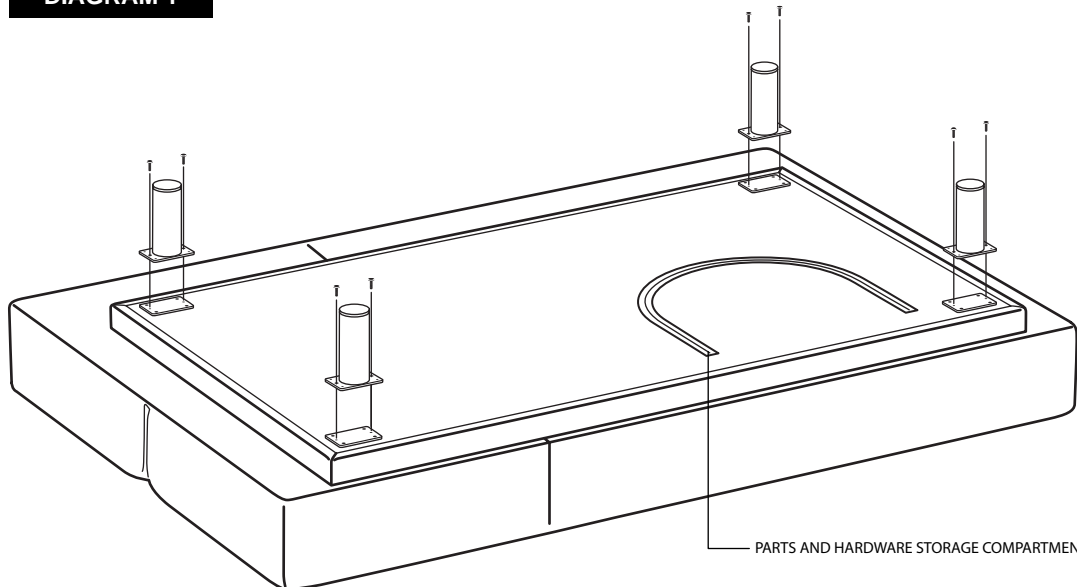
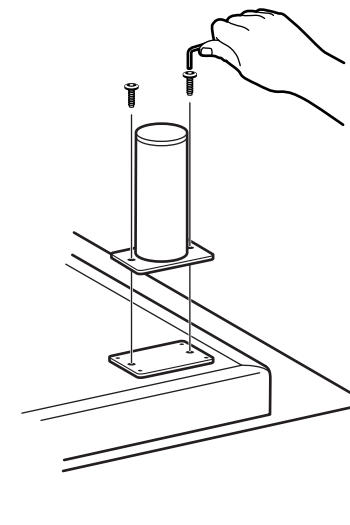

DIAGRAM 2



OPERATING YOUR UNIT

Converting to Sofa or Lounger

Standing at the side of the unit (from bed position), lift backrest to the desired position and secure in place by releasing to the sound of a *click*.

Converting to Bed

To return to a bed position (flat), lift backrest all the way up to the end, releasing the locking mechanism.

Converting to Chaise

Ensure unit is in bed position. Facing sofa, lift right side of sofa seat (and backrest) to the desired chaise position.

IMPORTANT

Ensure that the support legs are extended out (behind the backrest) when using it as a bed.

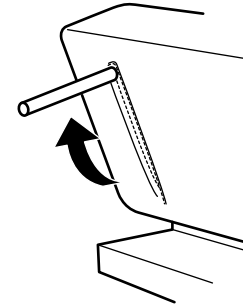

SOFA

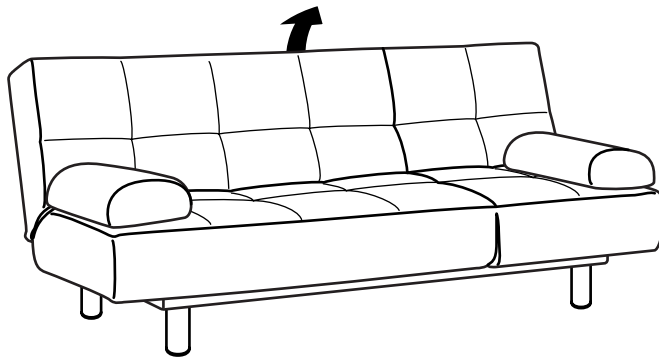

LOUNGER

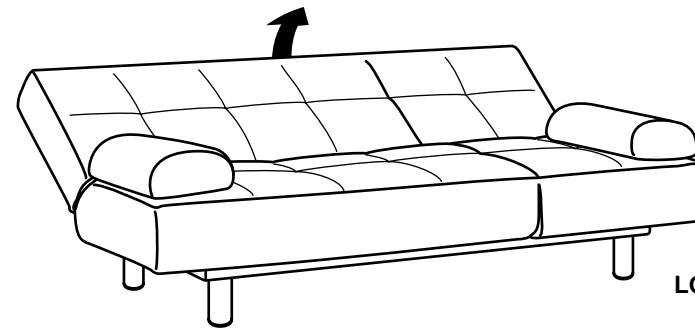

CHAISE

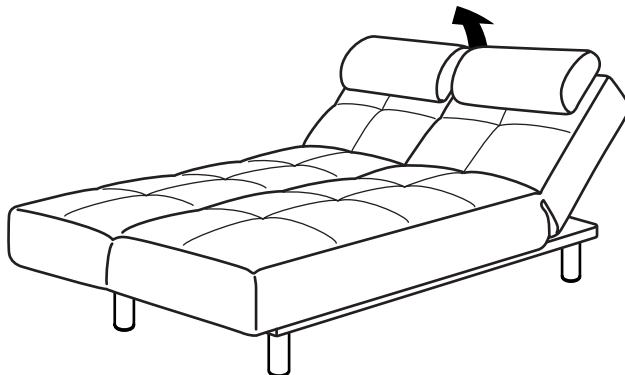

BED

