

# ROXBURY

## Assembly Instruction

Note: Avoid using sharp objects such as a knife to cut open the shrink wrapping packing as you may accidentally damage the sofa fabric.

1. Remove the attached Bolt A from the storage as shown in diagram 1.
2. Place the sofa on the storage box and assembled it with Bolt A as shown in diagram 2.
3. Lift the attached body with storage box and slot into the arm as shown in diagram 3 and 4. Ensure the metal plates are locked in.
4. Use the pull-out small leg as shown in diagram 5 for support.



**HEAVY WORK !!**  
3 people required  
to perform this exercise



Function A



Function B

### Parts and Hardware



M8 X 40mm JCBC  
Bolt - 4pcs (Bolt A)



Allen Key -1pc

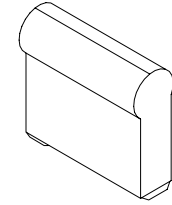

Arm - 2pcs  
(Part C)

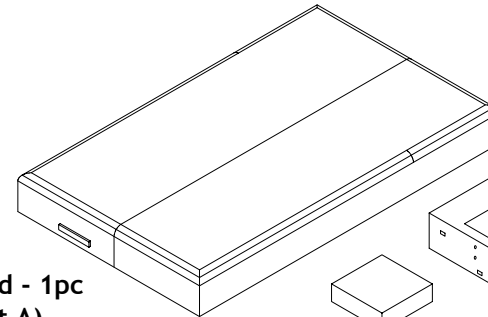

Sofa Bed - 1pc  
(Part A)

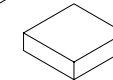

Small Pillow - 2pc

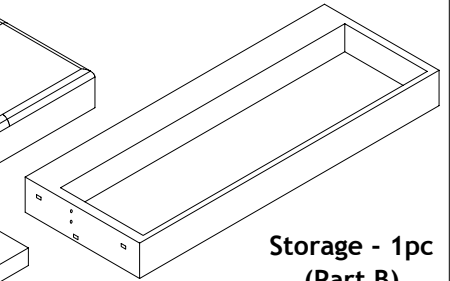

Storage - 1pc  
(Part B)

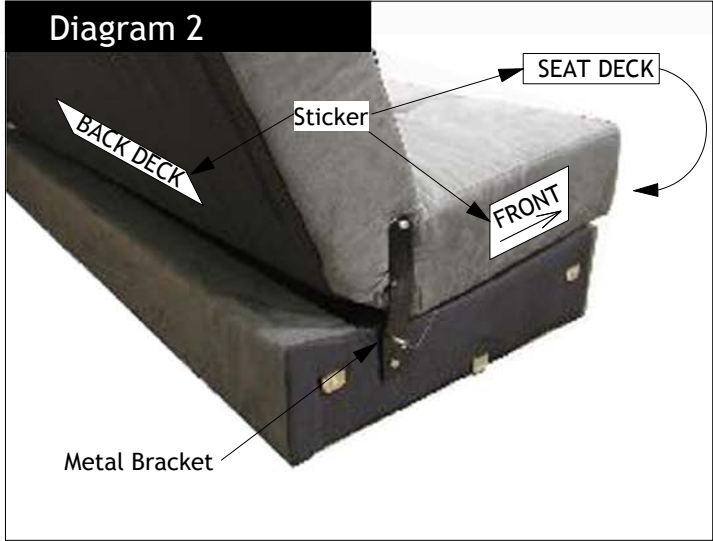
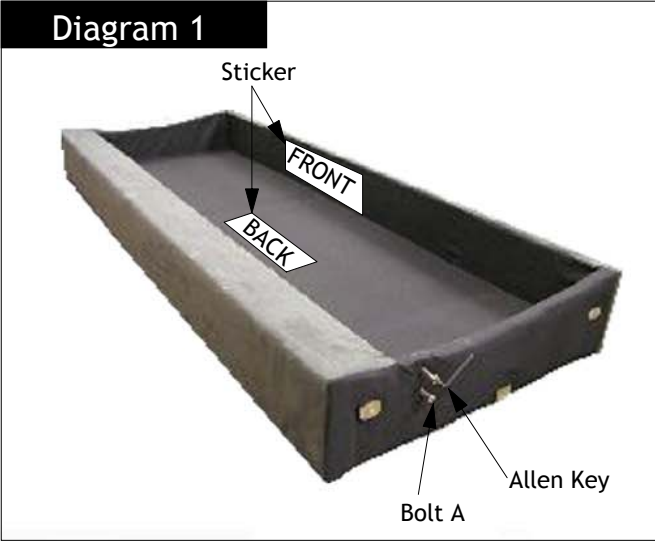

**CONVERSION METHOD**  
WHEN CONVERTING, ALWAYS ENSURE THAT YOU PLACE YOURSELF IN THE MIDDLE OF THE CASUAL CONVERTIBLE

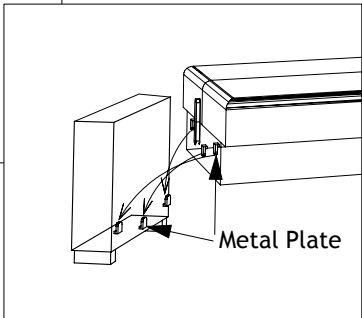

**Diagram 5**



\*Please remove stickers after assembly  
Pictures for illustration only